



CR-750

CR-750S

Motorized Patient Chair

CR-750 CR-750S

S e r v i n g y o u r v i s i o n



Three Seat Colors Available

Choose your preferred color from the following: blue, pink, or green.



Pink

Blue

Green

Large Elevation Stroke for All Patient Heights

Minimum chair height is now approximately 30mm lower than that of the previous model, accommodating all patient heights sufficiently with a large 150mm elevation stroke.

Up / Down Switch Equipped as Standard

New CR-750 / CR-750S chairs can be raised and lowered with the Up / Down switches located on the lower back of the chair, allowing medical assistants to quickly and conveniently adjust the chair height.



CR-750S: for integrated use, requiring no foot pedal

By connecting to the Ophthalmic Workstation, Smart Table, or Electric Instrument Table, the chair elevation can be controlled by the buttons on the instrument table. More comfortable legroom is achieved as there is no need to place a foot pedal on the floor.

*Contact our Sales Department with the serial number of the product you use.

Slide Mechanism (factory option)

By fitting a slide mechanism, the chair can slide forwards up to 60mm while the patient remains seated, allowing the patient to be situated closer to the instrument for examination if required, without moving the entire chair.

*Factory option only, not sold separately.

Round Seat (user option)

Square seats are supplied as standard, a round seat can be supplied as an option. Seats are easily installed with screws at four locations.

Specifications

Elevation stroke	150mm
Allowable load	up to 150kg
Input Power	AC120-230V 50/60Hz
Power consumption	120VA
Weight	26.5kg (CR-750)
	25kg (CR-750S)

Dimensions

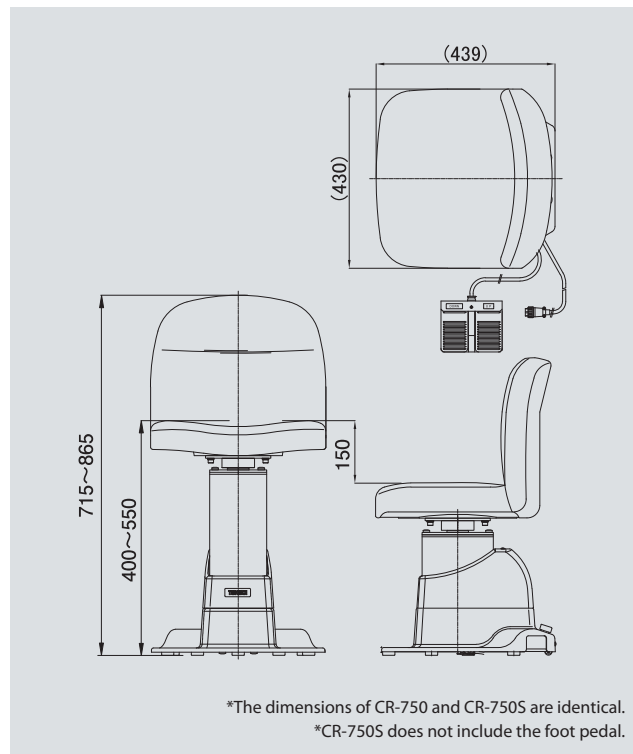

● Design and specifications are subject to change as improvements are made to the product.

TAKAGI SEIKO CO.,LTD.

330-2 IWAFUNE, NAKANO-SHI, NAGANO-KEN, 383-8585, JAPAN
TEL.+81-269-22-4512 FAX.+81-269-26-6321
URL:<http://www.takagi-j.com> E-mail:info@takagi-j.com

